



Changes for the Better

MITSUBISHI CNC
M70V Series

M70V
series



The Best Partner for Your Success

for a greener tomorrow



Further progress to the new MITSUBISHI standard CNC

Higher cost-performance for realizing higher-grade machines

- | | | | |
|--|--|---|---|
| <p>High Speed
Performance</p> <p>Multi Axis
Machining Control</p> <p>NANO
Control</p> | <p>[High-speed]
Cycle time reduced with higher machining-control performance</p> <p>[Multi-axis control]
Multi-axis control and two-part systems for compatibility with various machines</p> <p>[Nano interpolation]
Smoother cutting surface is achieved with one-nanometer position interpolation</p> | <p>OMR
Control</p> <p>NAVI
NAVIMILL
NAVILATHE</p> <p>Custom CNC
Solution</p> | <p>[High-accuracy]
High-accuracy tapping with high-speed compensation control of spindle and servo</p> <p>[Easy operation]
Simple programming system for machining center and lathe</p> <p>[Customize]
Development tools for providing a CNC with customized solutions</p> |
|--|--|---|---|

M70v Type A

Max. number of part systems	2
Max. number of axes	11
Max. number of NC axes (in total for all the part systems)	
Machining center system	8
Lathe system	9
Number of simultaneous contouring control axes	4
Least command increment	0.1 micrometer
Least control increment	1 nanometer
Max. PLC program capacity	32,000 steps

M70v Type B

Max. number of part systems	1
Max. number of axes	9
Max. number of NC axes (in total for all the part systems)	
Machining center system	5
Lathe system	5
Number of simultaneous contouring control axes	5
Least command increment	0.1 micrometer
Least control increment	1 nanometer
Max. PLC program capacity	20,000 steps

The Best Partner for Your Success

MITSUBISHI CNC

M70v series



Versatile lines boasting compact size and less wiring

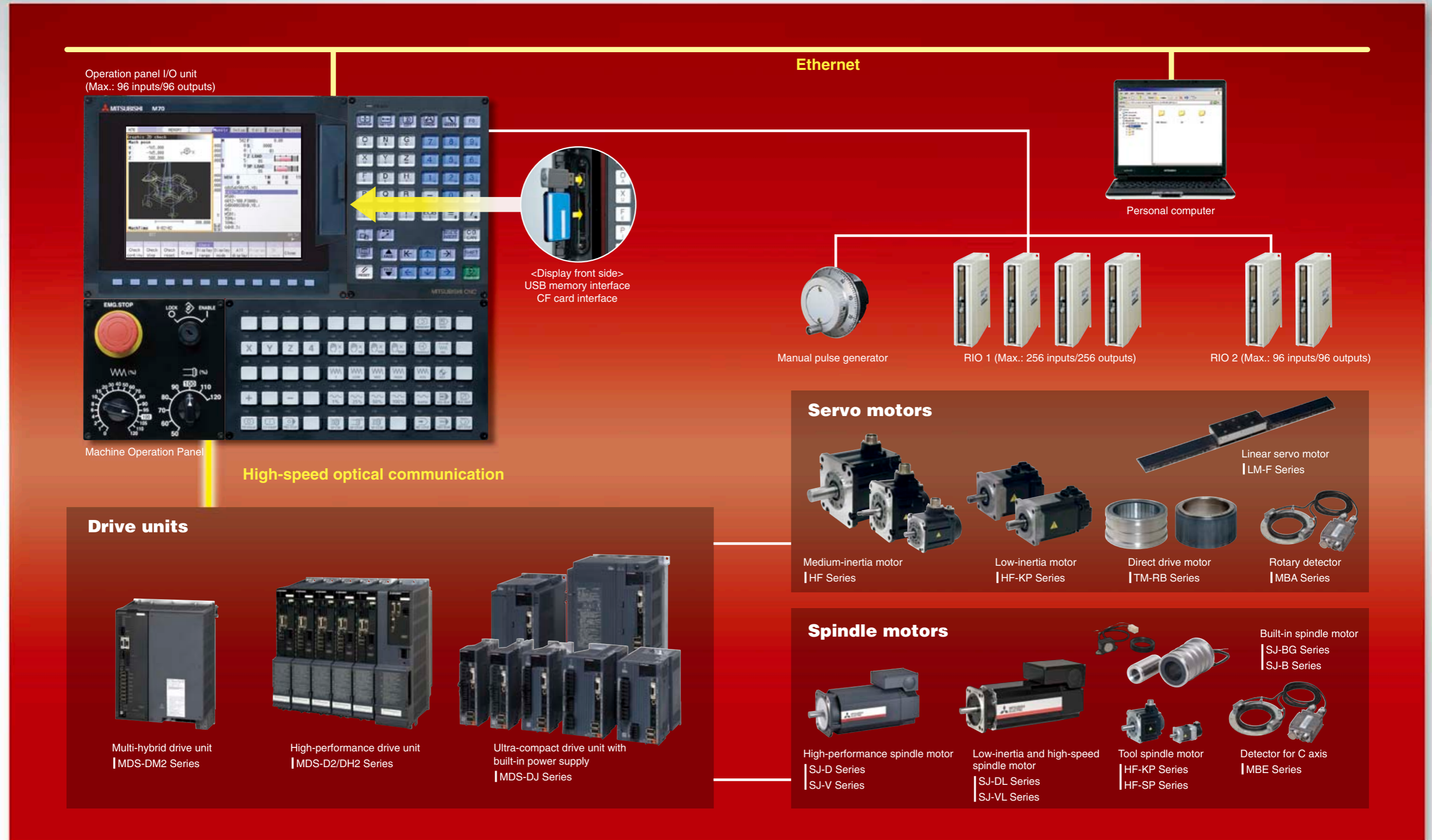

Higher-grade CNC performance attained

Remarkable reduction in cycle time



Basic Performance

Machining program

- Capacity
Machining program capacity is greatly enhanced to the standard of 500kB [1,280m].
- Processing speed
TypeA: 33.7k blocks/minute TypeB: 16.8k blocks/minute

Built-in PLC function

- Multi-program
Up to 20 PLC program files can be registered, which are executed according to priority. A PLC program can be split into each process and developed.
- High-speed PLC engine installed (TypeA)
TypeA is equipped with a high-speed PLC engine, helps enhance the performance.

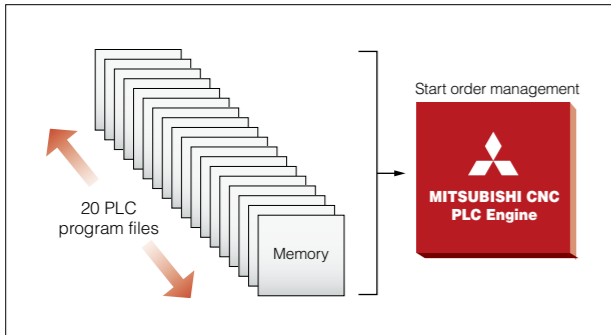

Multi-part Systems Multi-axis



A maximum of two part systems and 11 axes can be controlled for both the machining center and lathe.

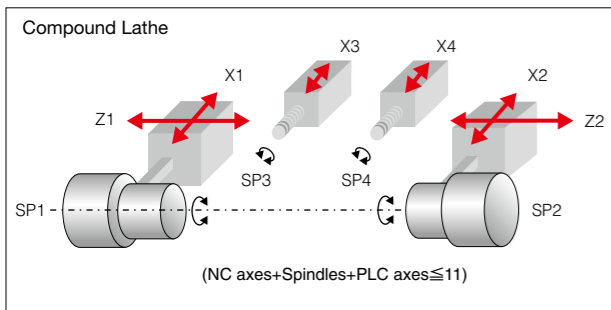
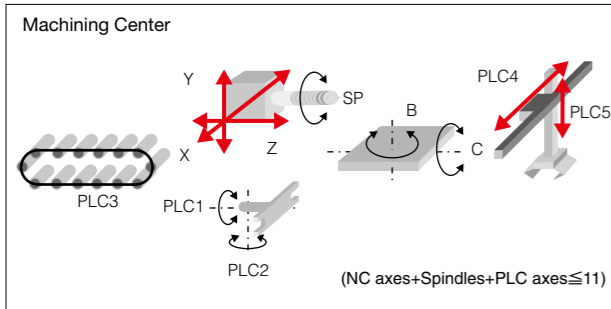

Nano Control



The least control increment is one nanometer, the command increment is ±99999.9999, and the rapid traverse rate is 1000m/min. All processing from the analysis of machining programs to servo commands is performed in nanometers.

Speed command fluctuation reduced

In nano control, the position command calculation fraction of the interpolation calculation is small, so fluctuations in speed command due to the fractions is reduced. This reduces acceleration fluctuations, resulting in finer lines at the time of repeated acceleration/deceleration.

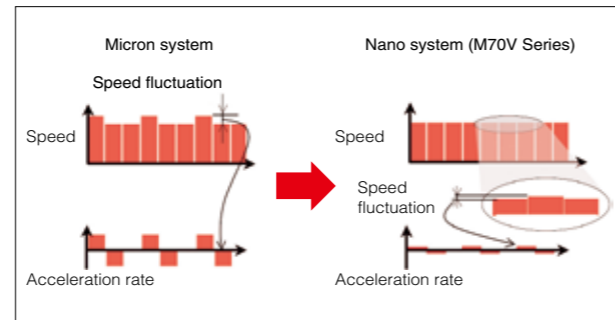

Interpolation calculation accuracy improved

Even with one-micron-unit commands in the machining program, interpolation is in nanometer units. As the calculation accuracy of a block intersection is improved, lines on the surface is finer.

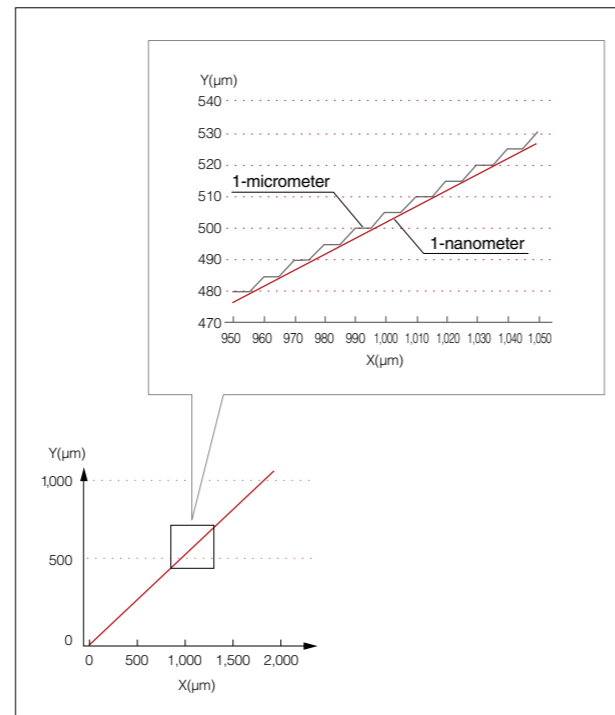

OMR-DD Control (High-speed synchronous tapping)



Optimum Machine Response Direct Drive

A high-speed error-compensation function is used for controlling the spindle and servo, enabling accurate tapping.

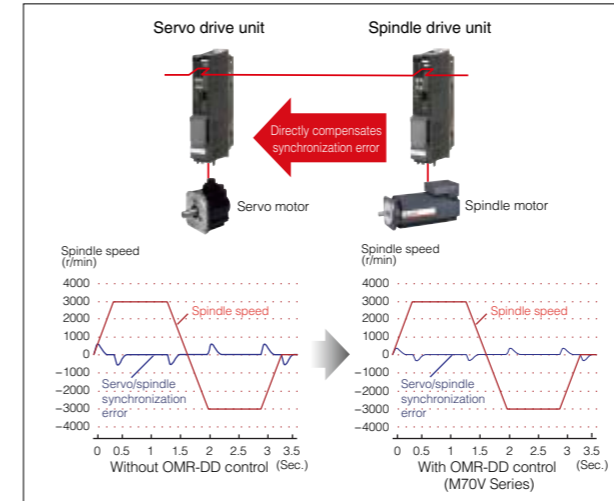

High-speed Machining Mode



(Machining Center System)

By reading ahead some blocks in a program that contains successive fine travel distances, the program can be rapidly executed at up to 33.7k blocks/minute. (8.4k blocks/minute for TypeB)

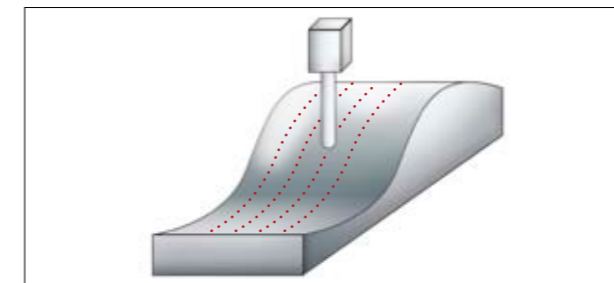

Rapid Traverse Constant Inclination

Multi-step Acceleration/Deceleration Function



(Machining Center System)

*1st part system only

- Rapid traverse acceleration/deceleration is performed according to the motor's torque characteristics.
- As the motor's characteristics can be utilized optimally, positioning time is reduced, and cycle time is improved.

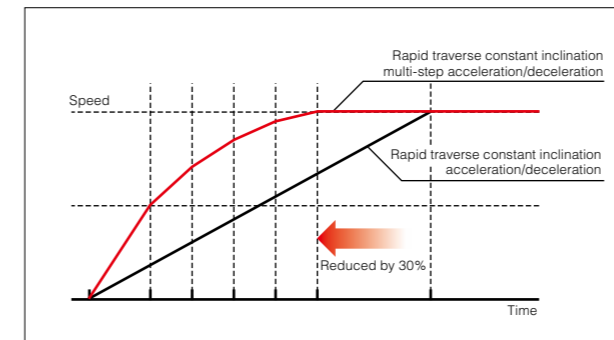

Position Loop of Spindle Control



High traceability to command (High-gain control II), which has been developed in servo axis control, is now available for the spindles, contributing to shorter machining time and higher accuracy.

Spindle/C-axis control

The spindle's constant position loop control has eliminated the zero point return time when switching from the spindle to C-axis.

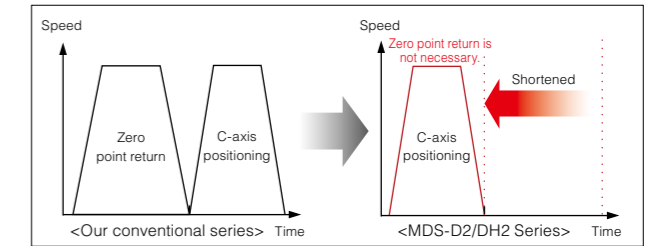

Orientation time is reduced

Deceleration is performed with the maximum torque to minimize the spindle orientation time.

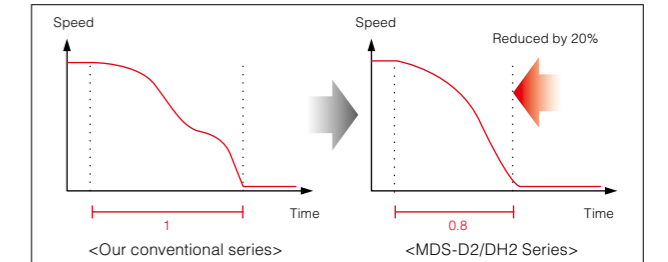

SSS Control



(Machining Center System)

* TypeA only
Super Smooth Surface

By judging shapes in large from commanded paths, unnecessary deceleration is reduced even when fine steps exist; thereby, realizing smooth and deviation free die-mold machining. Machining time can be shorter by 5 to 30% relative to our conventional system, especially more effective at a higher feed rate.

(Note) Additional hardware is required. In order to use this function also in the 2nd part system, the option "High-accuracy control in 2 part systems" is required.

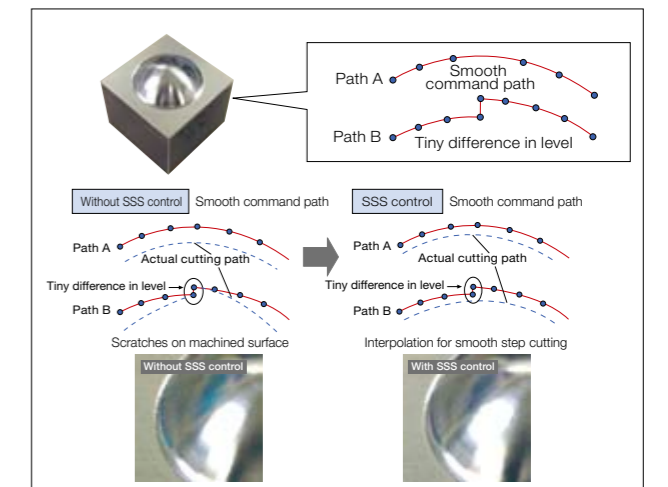

Multi-part System Program Management (TypeA)

Separate programs, used in each part system, can be managed under a common name in the multi-part system. This function facilitates management of the process programs that are simultaneously executed in the multi-part systems.

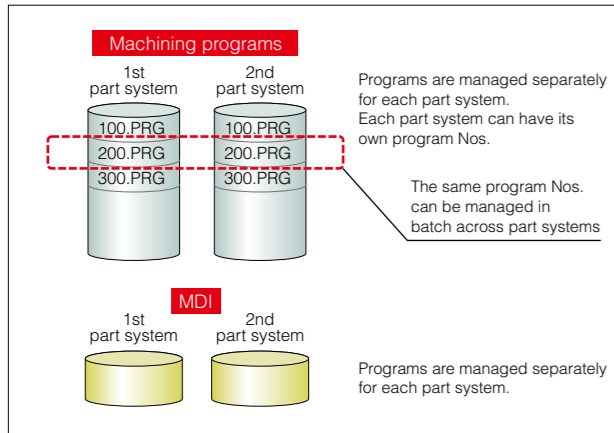

Polar Coordinate Interpolation

- This function converts the commands programmed for the orthogonal coordinate axes into linear axis movements (tool movements) and rotary axis movements (workpiece rotation) to control the contours.
- It is useful for tasks such as cutting linear cutouts on the outside diameter of the workpiece and grinding camshafts.

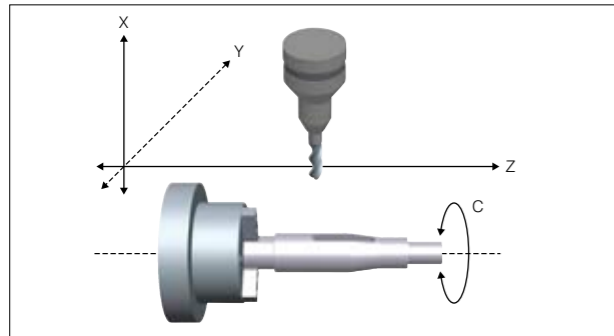

Milling Interpolation (TypeA)

This function converts the commands programmed for the orthogonal coordinate axes into linear axis movements (tool movements) and rotary axis movements (workpiece rotation) to control the contours. This enables milling operations using a lathe without a Y axis.

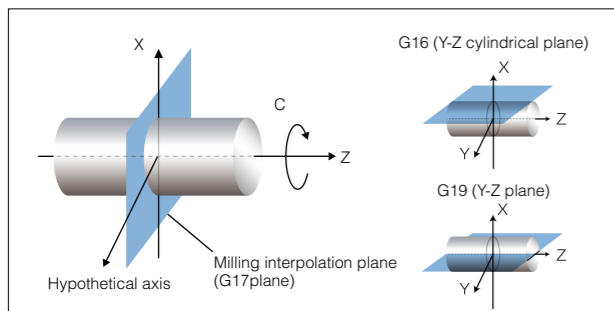

Inclined Axis Control

- Even when the control axes configuring a machine are mounted at an angle other than 90 degrees, this function enables it to be programmed and controlled in the same way as with an orthogonal axis.
- The inclination angle is set using a parameter, and axes are controlled using the movement amounts of the axes which are obtained through conversion and compensation using this angle.

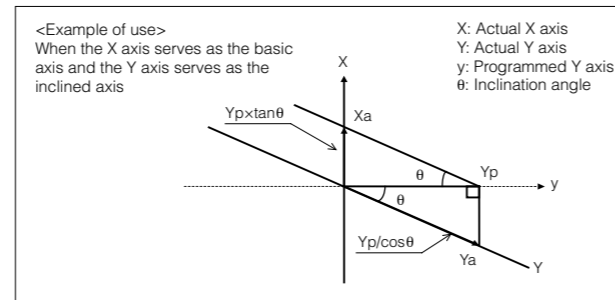

Hobbing (TypeA)

- G code format is available for hobbing.
- A spur gear can be machined by synchronously rotating the hob axis and the workpiece axis in a constant ratio. A helical gear can be machined by compensating the workpiece axis according to the gear torsion angle for the Z axis movement.

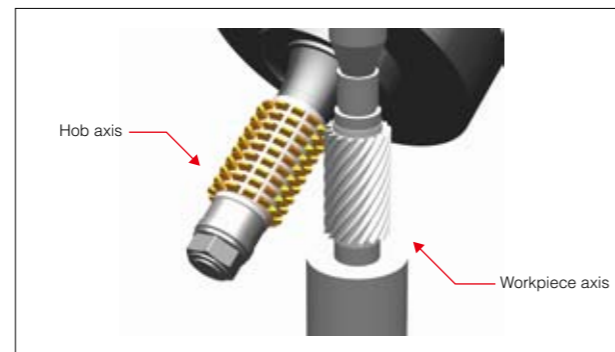

Mixed Control (cross axis control) (TypeA)

The control axes of each part system can be exchanged using a program command. This enables the axis defined as the axis of the 1st part system to be operated as the axis of the 2nd part system.

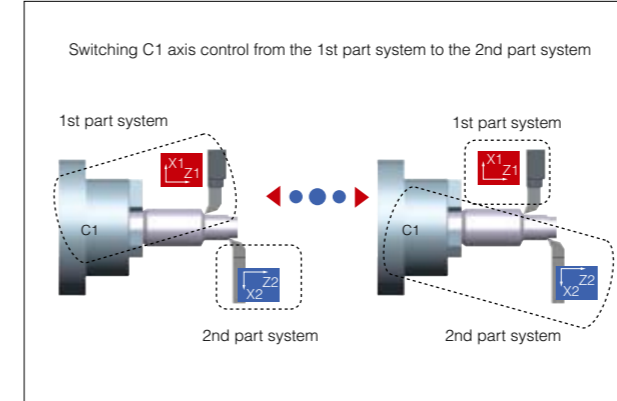

Control Axis Synchronization Across Part Systems (TypeA)

Synchronization control enables an arbitrary control axis in the other part system to move in synchronization with the movement command assigned to an arbitrary control axis.

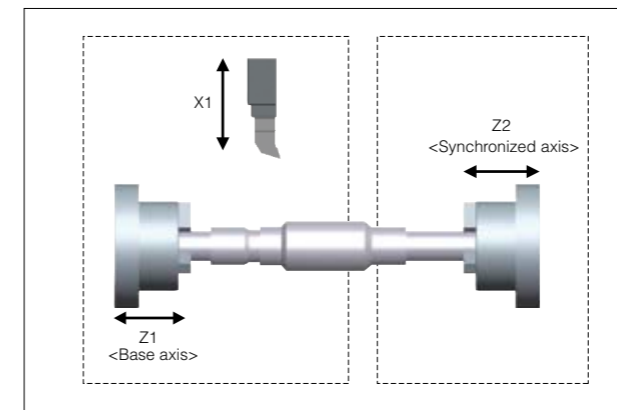

Balance Cut (TypeA)

- Deflection can be minimized by holding tools simultaneously from both sides of the workpiece and using them in synchronization to machine the workpiece (balance cutting).
- The machining time can be reduced by machining with two tools.

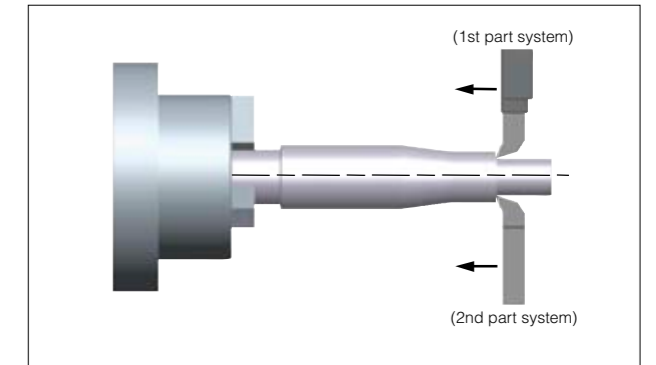

2-part System Synchronous Thread Cutting (TypeA)

- 2-part system synchronous thread cutting allows the 1st part system and the 2nd part system to perform thread cutting simultaneously for the same spindle.
- 2-part system synchronous thread cutting has two commands; command (G76.1) for cutting threads in two places simultaneously, which is known as "2-part system synchronous thread cutting cycle I"; and command (G76.2) for cutting a thread using the two part systems simultaneously, which is known as "2-part system synchronous thread cutting cycle II".

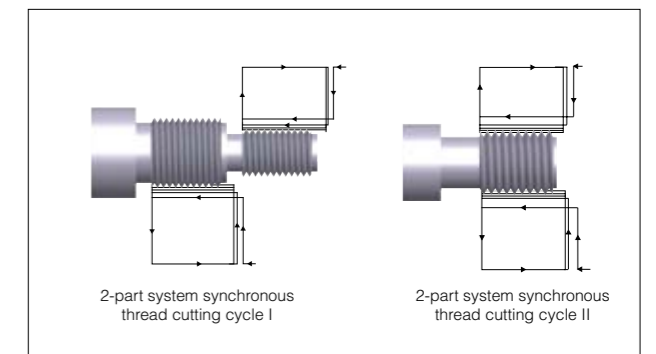

Machining Center System

Compact Milling Machine

The compact operation board, in which the control unit is integrated, and the ultra-compact drive units achieve downsizing of the control board and machine.

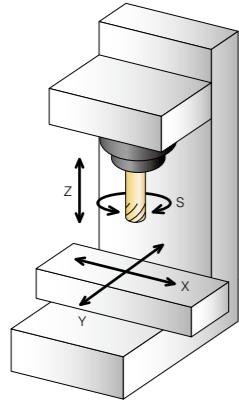

Tapping Machine

The multi-hybrid drive unit optimally controls the spindle motor for tapping to bring out the function of high-speed tapping OMR-DD. An NC five-axis control (simultaneous four-axis) enables control of the tilt table.

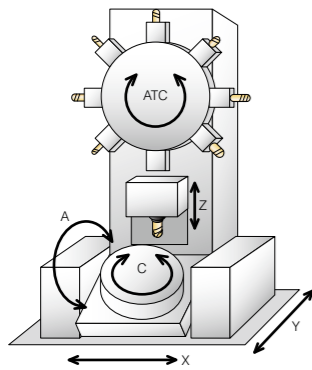

Multi-axis Machining Center (TypeA compatible)

A system with a maximum of 11 axes and two part systems achieves optimal control even for a compound axis configuration that includes a synchronization axis and a peripheral axis, such as in a large machine or in a line dedicated machine.

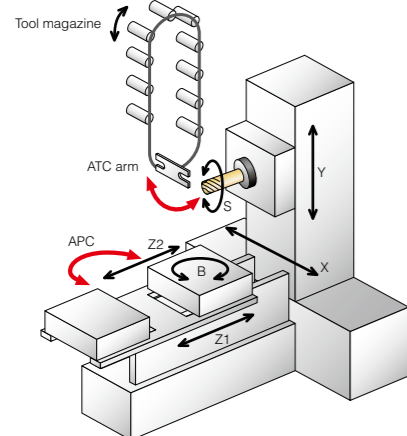

Lathe System

Compact Lathe

The compact operation board, in which the control unit is integrated, and the ultra-compact drive units achieve downsizing of the control board and machine.

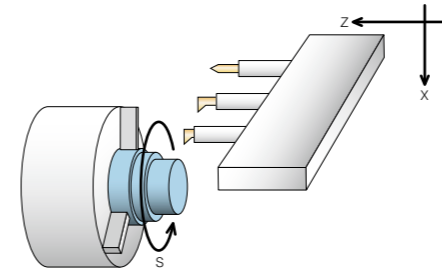

Milling-enabled Lathe (TypeA compatible)

Even without a Y axis, the milling function enables contour control machining on the side or face of a workpiece. Furthermore, the tool spindle motor contributes to downsizing of the turret.

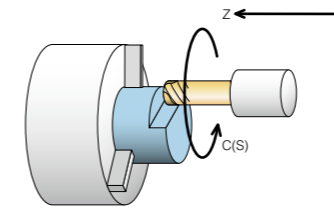

Compound Multi-axis Lathe (TypeA compatible)

Up to four spindles can be controlled by a system with a maximum of 11 axes and two part systems. Owing to the drive units that drive three servo axes/two spindles, we offer an optimal system construction for machines of various axis configurations.

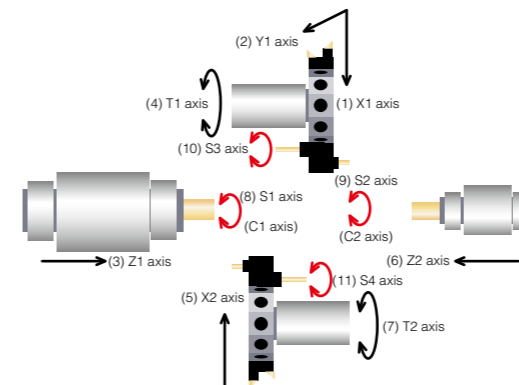

HMI for Easier and More Visible Use

(HMI:Human Machine Interface)

Screen structure linked to operation processes

Operation processes are divided into three steps, "Monitor", "Setup" and "Edit", and necessary information is aggregated into three screens. These screens can be displayed by touching a single button on the keyboard.

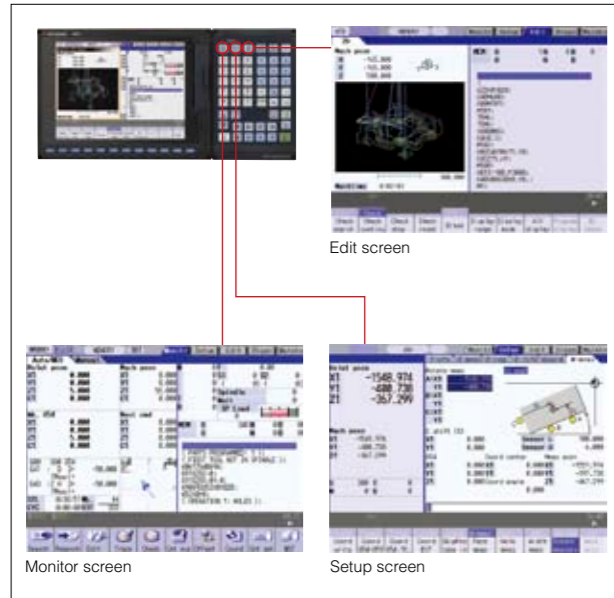

2-part system display

The Monitor screen of the 2nd part system can be displayed together with the 1st part system. Switching screens is not necessary.

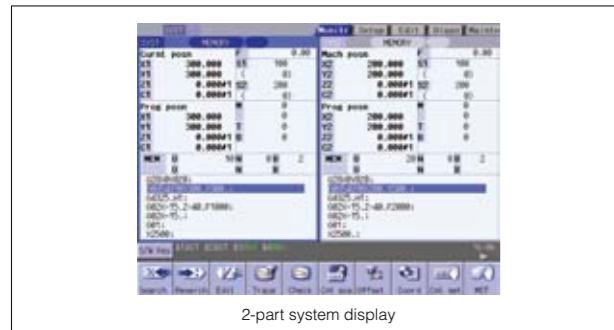

Auto-scale adjustment of the graphic check function

When the automatic graphic check function is enabled, by selecting a file, the scale is automatically adjusted to draw the whole machining path. (In single-plane display mode)

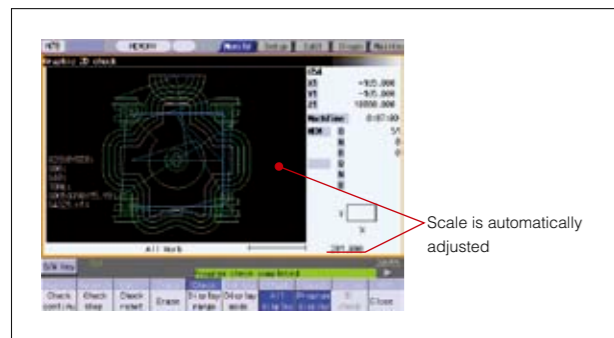

Pop-up screens

Tab allow the user to select necessary operations from the operation menu, and pop-up screens allow the user to access desired information while the original screen remains displayed. For displays with a touch panel, a keyboard can be displayed on the screen.

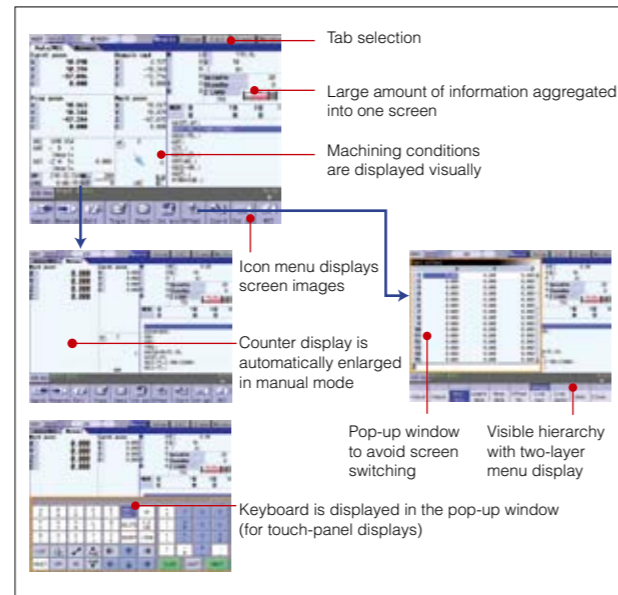

Menu customization function

Menu keys on the bottom of the screen can be freely arranged. Frequently used menu keys can be put together on the first page.

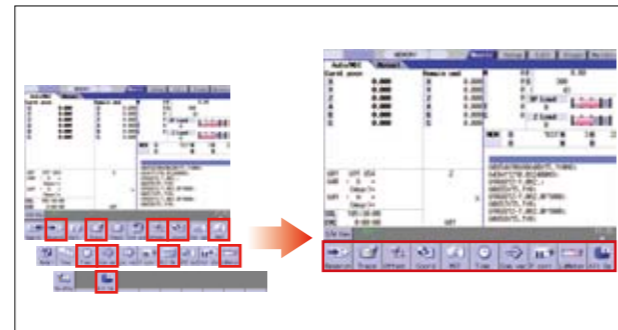

3D solid program check

The added 3D solid model check function allows more realistic cutting check.*



*Available with M70V TypeA (M System) only.

Operation Support

Manual/Automatic backup function

- Batch-backup of the NC data into the CF card/USB memory inserted in the front interface of the display is possible.
- Data is automatically backed-up at a certain interval set by the parameter.



Operability of program restart function improved

Even if a machining program is stopped for reasons such as tool breakage, the program can be restarted when it has been stopped using only the INPUT operation.

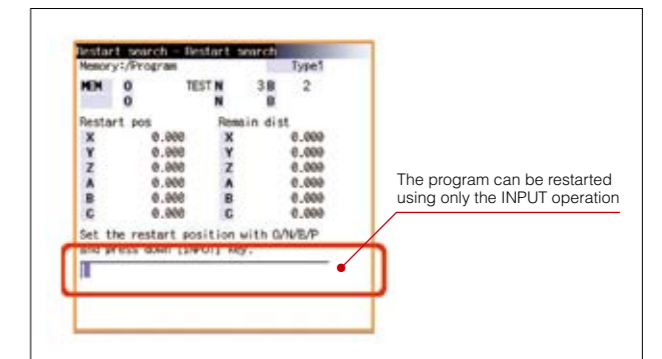

Operability of operation search improved

Using the program edit screen, it is possible to execute a program from the line specified by the cursor. The operation search immediately detects the edited part to check the content of operation.

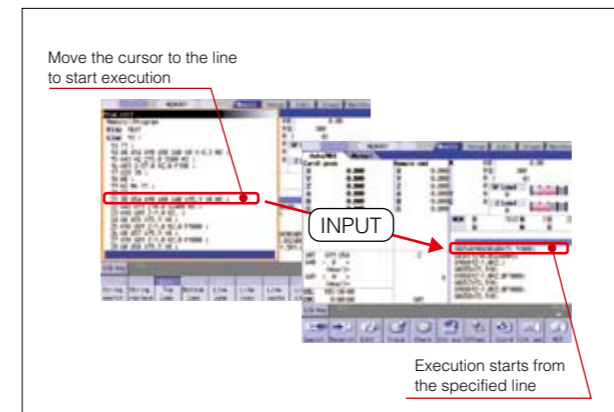

Menu list

Menu list buttons are newly introduced. With these buttons, the screen desired for display can be called up directly. The selected screen's function outline is also displayed.

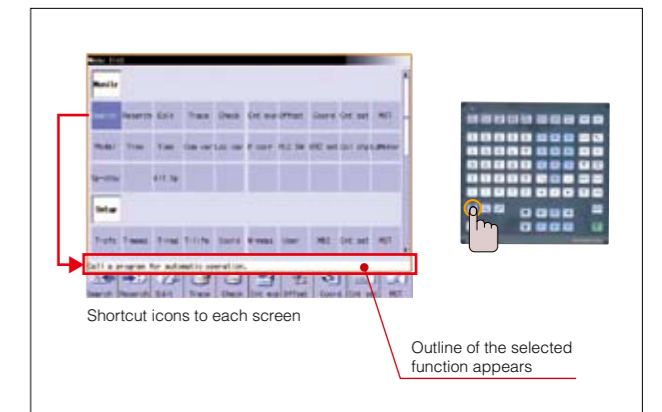

Guidance function

By pressing the help button, guidance (operation procedure/parameter descriptions/alarm descriptions/G code format) regarding the currently displayed screen will be shown.

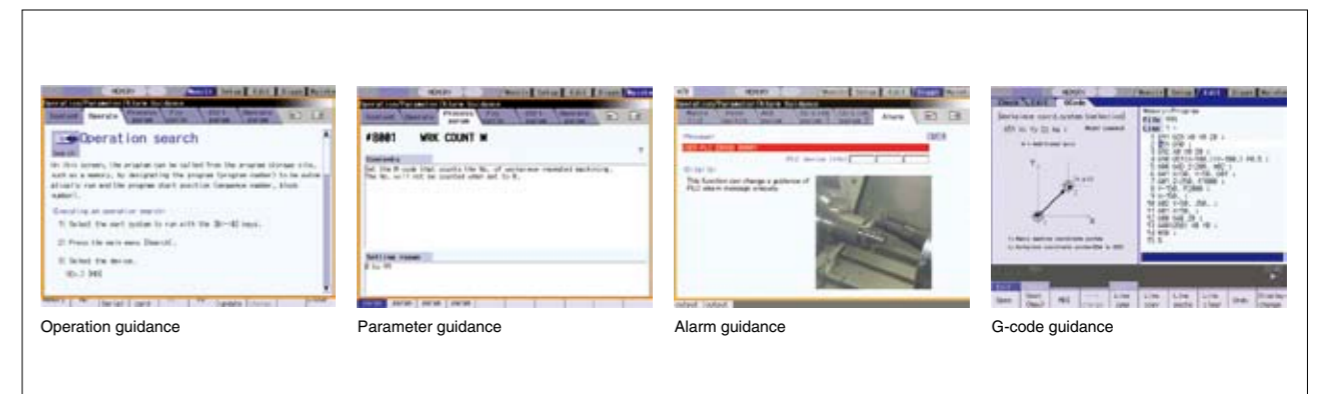

Easy to import external data

Various support functions minimize downtime



Memory Card/USB Memory Interface

A compact flash memory card (CF card) /USB memory interface is located on the front of the display. In using CF card, the card slot can be completely covered by a lid so as to prevent foreign materials from entering (IP67).

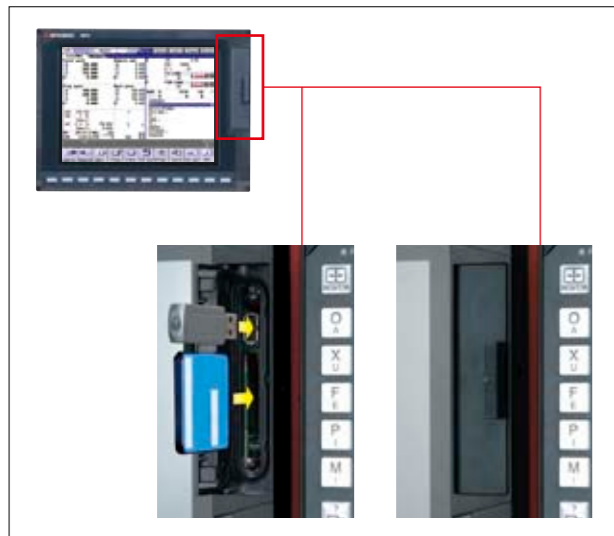

Front IC Card Mode

- It is possible to directly search and run the machining programs from the CF card. Subprogram calls are also available.
- The machining programs in the CF card can be edited directly.

Easy to Change Languages

- Display languages can be switched with a single parameter operation.
- Easy to change languages of the guidance function using a CF card. (English + Two more languages are selectable)
- Support for 17 languages, securing reliable use worldwide.

Languages supported	
Japanese	Portuguese
English	Hungarian
German	Dutch
Italian	Swedish
French	Turkish
Spanish	Polish
Chinese (traditional)	Russian
Chinese (simplified)	Czech
Korean	

Ethernet Communication

By connecting a personal computer and an CNC via Ethernet, the machining programs and parameters can be input and output.

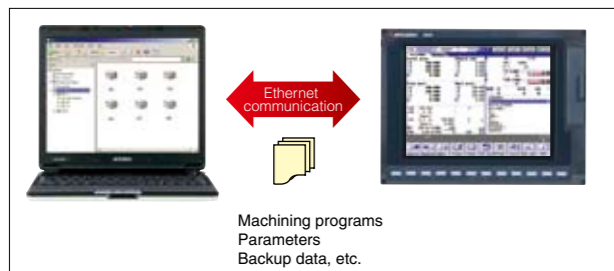

<Application example> Remote monitor via tablet PC

When combined with Ethernet, NC Monitor enables remote monitoring via a tablet device. Within reach of wireless LAN, NC Monitor can display on a tablet PC an NC screen that is running on a shop floor. This allows an operator who is distant from worksite to remote monitor program running state and presence of alarms, etc. This application also serves as a sub monitor of large-size or difficult-to-approach machines.

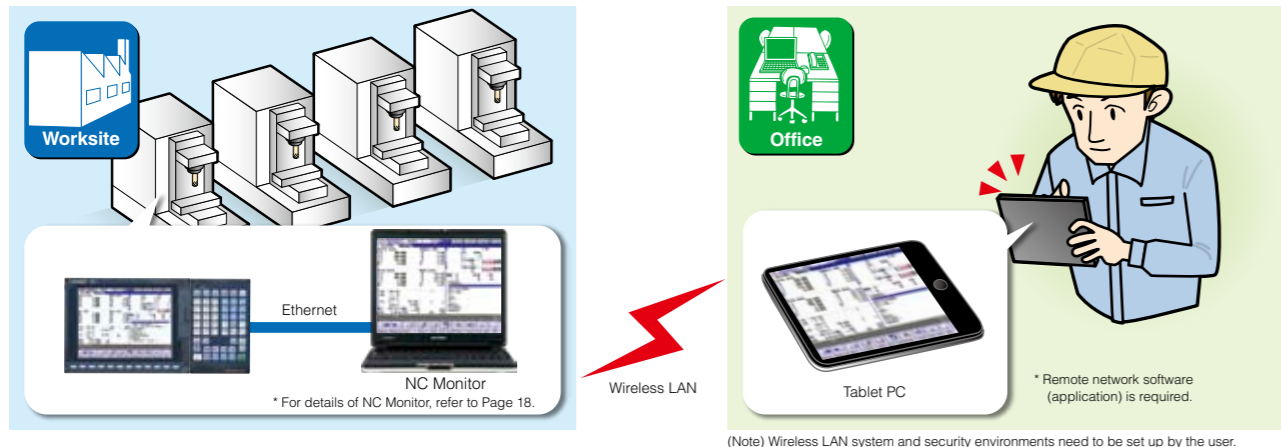

Data Backup Function

It is possible to backup NC data collectively and periodically to a CF card /USB memory on the front of the display. This backup data is helpful for restoring the system in the case of an accident.

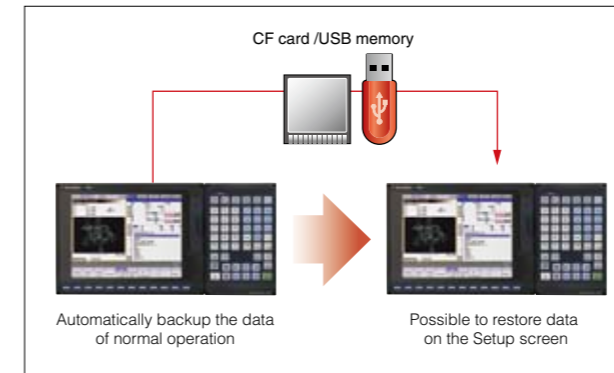

Tapping Retract

Even when tapping is interrupted due to emergency stops or power outages, retraction of the tool out of a workpiece can be automatically carried out upon restarting operation.

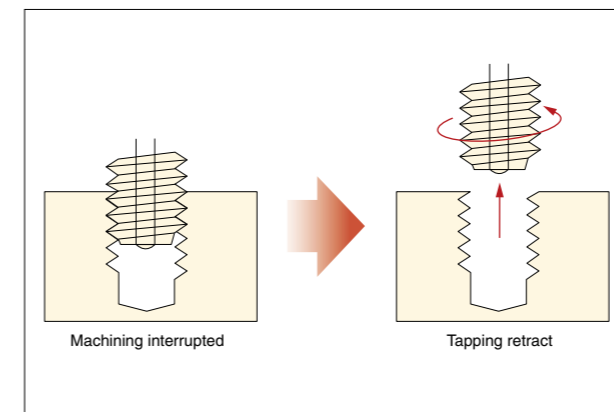

Ground Fault Detection for Each Motor

Ground fault detection, which was formerly centrally performed by a power supply unit, has changed so that the fault can be detected per motor. As detecting a faulty axis is possible, the restore time is shorter.

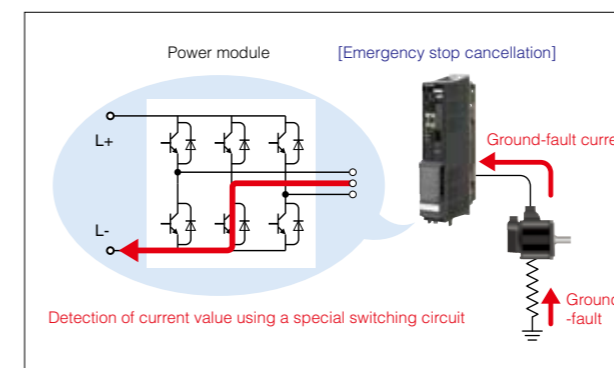

Program Restart Function

It is possible to restart a program even when a machining program is interrupted due to tool breakage or power outages by automatically searching the block that was last executed before the interruption.

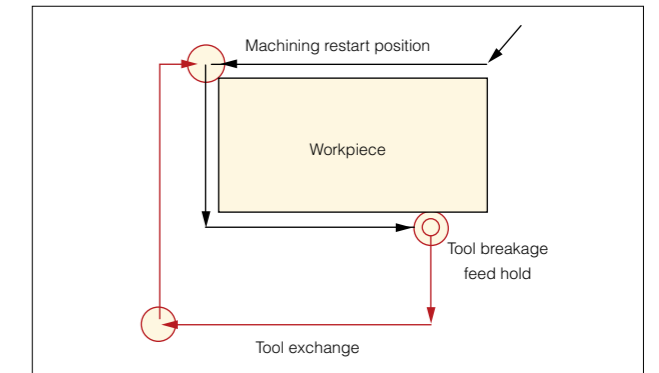

Vertical Axis Drop Prevention Function at Power Failure

The drive system instantly detects a power failure, and the gravity axis is retracted so as to prevent a crash with a workpiece.

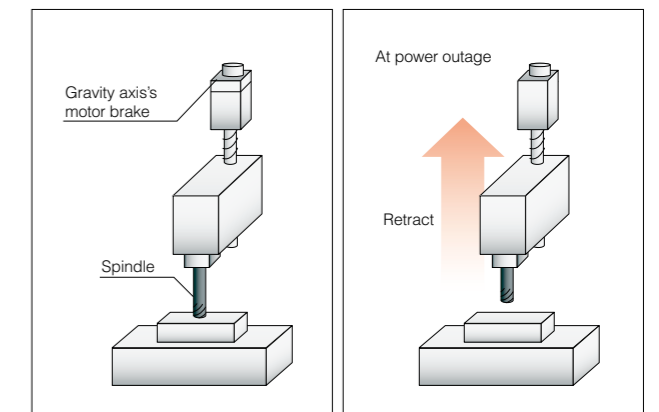

Drive Unit with Higher Oil-proof

A cooling fan for the radiator fin outside the panel is molded so as to further prevent the oil from entering. The absence of a fan inside the drive unit contributes to the avoidance of electric circuit failures caused by inhaled dust and oil-mist.

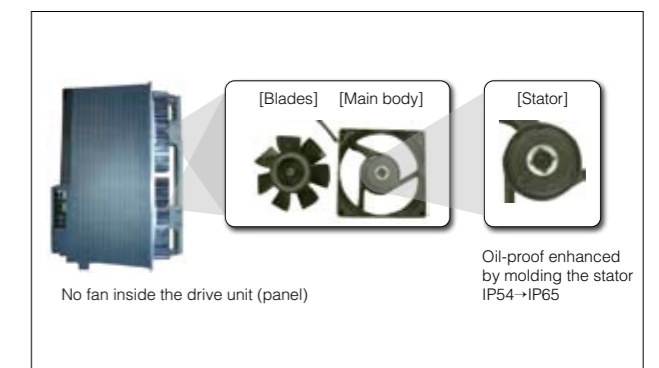

Simple programming tools, "NAVI MILL" and "NAVI LATHE"



Interface Design with Overall View

Intuitively view system configuration and machining programs

LIST VIEW

LIST VIEW displays objects such as programs, processes, file data and parameters.

OPERATION VIEW

OPERATION VIEW displays the items corresponding to the object selected in LIST VIEW. Data can be input easily referencing the guidance drawing for input items.

Automatic Setting of Cutting Conditions

Simply input the tool number. The cutting conditions for each process are automatically set based on previously registered tool files and cutting-condition files.

Checker and Guidance Functions

Detects input errors for troubleshooting.

Message guidance

Troubleshooting options for input errors are displayed.



Parameter guidance

Displays parameter details and setting range.

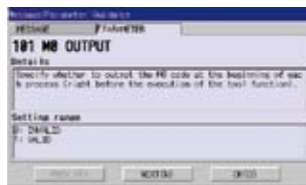

Tool guidance

Displays primary data of the tool data previously registered in the tool file.

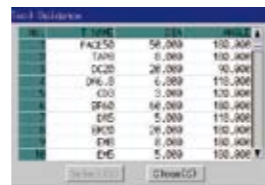

Checker

Displays the tool path or machining shape of a program in graphic form.

NAVI MILL

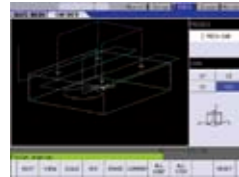

NAVI LATHE

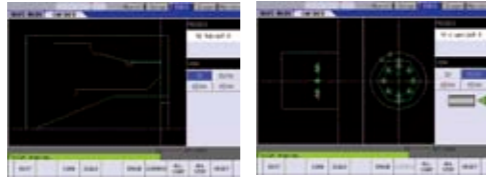

Customize Machining Programs

Machining programs using macro programs enable commands to be added between processes via the editing screen.

Machine tool builders can customize the macro program of each process according to machine specifications and machining know-how.

Menu

NAVI MILL



Hole drilling



Face cutting



Contour cutting



Pocket machining



EIA

NAVI LATHE

Turning



Turning



Copying



Grooving



Trapezoid grooving



Thread cutting



Hole drilling



EIA



Cutting off

Milling

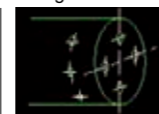

Milling

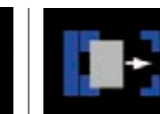

Holog by milling



Keyway



Contour cutting

Assist



Transfer

Create machining programs on a personal computer



NC Explorer (Data Transfer Tool)

By connecting the NC and host personal computer via Ethernet, data such as machining programs can easily be shared. This tool is free of charge. Please contact us.

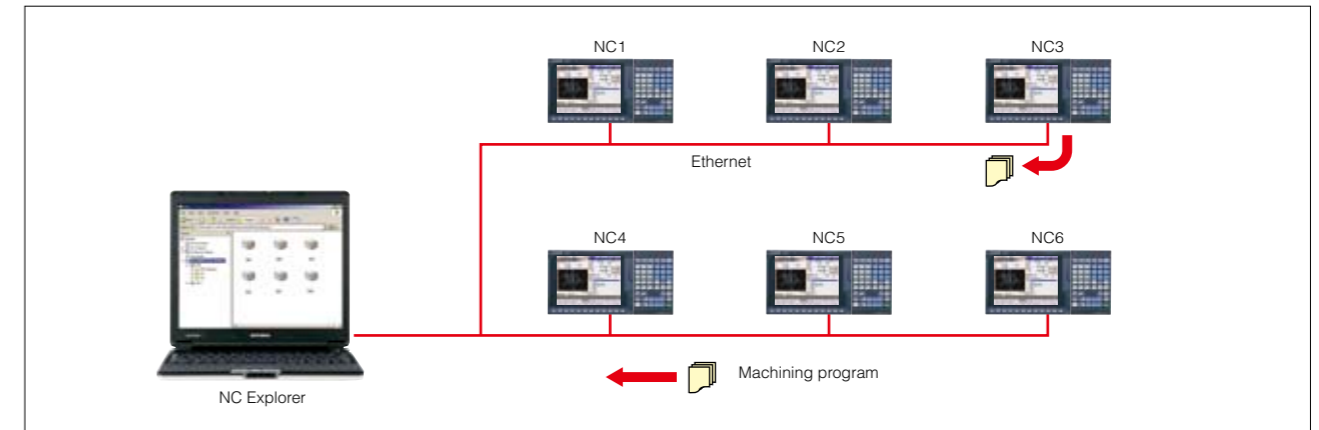

NC Trainer / NC Trainer plus (MITSUBISHI CNC Training Tool)

- NC Trainer is an application for operating the screens of MITSUBISHI CNC M70V Series and machining programs. This application can be used for learning operating CNC and checking the operations of the machining programs.
- NC Trainer plus can also be used for checking the PLC program and custom screens.



More comfortable development environment

<Custom screen development>

Make your CNC more user-friendly by developing original screens

NC Designer (Screen Design Tool)



- By laying out ready-made standard parts, you can easily create original screens without programming.
- When using a touch-panel display, a machine operation panel can be built on the NC display.
- Events of the standard parts can be described using macros.
- Using the C language source generation function of NC Designer, customized functions can be added by programming in C language. (Dedicated development environment necessary.)

Element	Outline
Screen	Physical display area
Panel	Base screen
Window	Pop-up window
Figure	Seven types of figures such as rectangles and circles
Control	Standard graphic parts such as buttons and lamps, and NC display parts such as counters and programs

Parts displayed on NC (example)

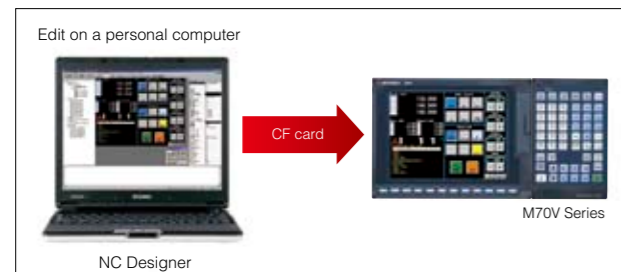

- Simply by locating parts of various functions on the screen, it is possible to create custom screens easily.
- It is possible to check the performance of custom screens on a personal computer.

Develop screen configuration

Resource window
Common information such as character strings, fonts and images is managed here; available among multiple controls.

GUI screen edit area
By locating controls offered by NC Designer, it is possible to design screens easily.
*GUI (Graphical User Interface)

Message window

Property window
Each control's attributes are managed as properties. It is possible to customize controls by setting the properties.

Controls
GUI parts used for screen creation with NC Designer. Standard parts such as buttons and NC dedicated controls are available.

<Sequence program development> Editable on both personal computers and HMI screens

GX Developer (Sequence Programming Tool)

The MELSEC programming tool, offering a wide array of functions and easy use, allows for convenient program design and debugging. Linking with a simulator or other utility allows for the efficient creation of desired programs.

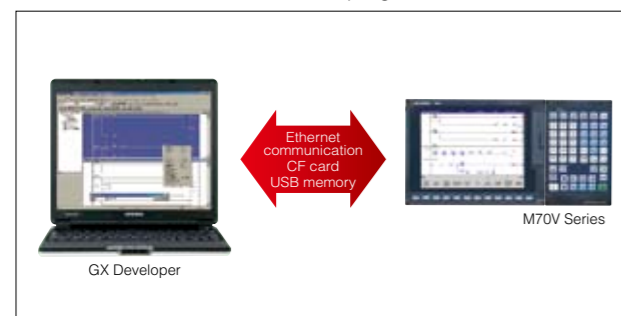

Onboard Ladder Editor

Operability of ladder editing/monitoring on the NC display is widely improved. Various functions are enhanced, such as divided screens, the search function and the monitoring screen.



<Easy setup>

Offering a wide range of support tools, from machine design to setup

Servo Selection Tool

By selecting the machine configuration model and inputting the machine specifications, the optimal servo motor meeting specifications can be selected. Other selection functions which fully support drive system selection are also available. This tool is free of charge. Please contact us.

<Main functions>
Servo motor capacity selection, regenerative resistor capacity selection, spindle acceleration/deceleration time calculation, power supply capacity selection, power supply facility capacity calculation, etc.

When the machine model and input specifications are selected, the selection result for the motor will be displayed. The result can be output in PDF format.

NC Configurator2 (Parameter Setup Support Tool)

The NC data file necessary for NC control and machine operation (such as parameters, tool data and common variables) can be edited on a personal computer. Please contact us to purchase a full function version. (A limited function version is also available free of charge.)

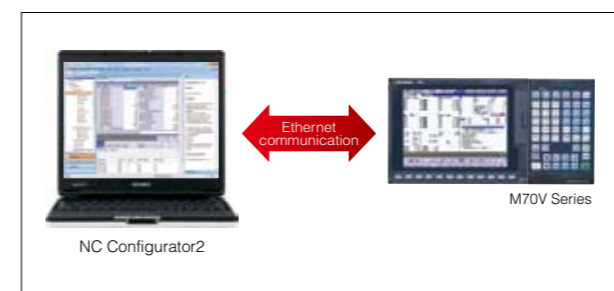

Setup Installer

Register the desired display language.



NC Monitor (Remote Monitoring Tool)

An identical NC display screen can be displayed on a personal computer. By connecting a personal computer to the NC unit when necessary, various data can be checked and set using the same HMI as the standard NC screen.

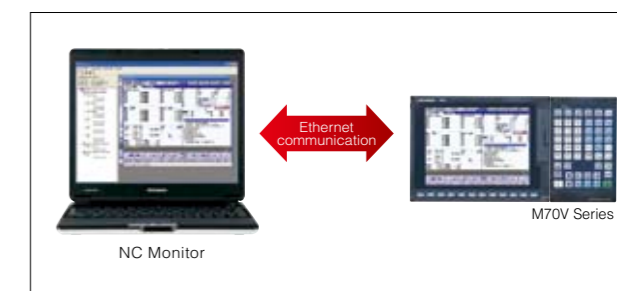

NC Analyzer (Servo Adjustment Support Tool)

Servo parameters can be automatically adjusted by activating the motor using machining programs for adjustment or vibration signals, and measuring/analyzing the machine characteristics.

<Main functions>
Bode diagram measurement display, speed loop gain adjustment, position loop gain adjustment, notch filter setting, acceleration/deceleration time constant adjustment, circularity adjustment and servo waveform measurement.

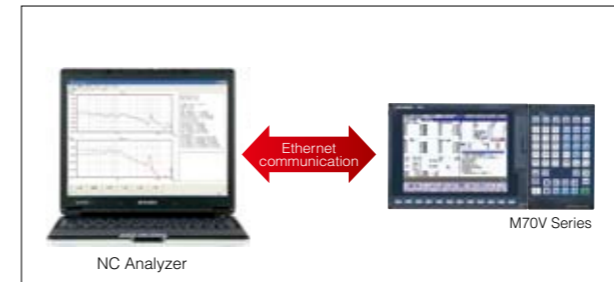

A wide range of support features according to various machine configurations

CC-Link

The NC unit can be connected to a network to serve as the master/local station of the MELSEC CC-Link.



Optical Communication Repeater Unit

The optical cable can be extended to a maximum of 90m by connecting up to two optical servo communication repeater units between the CNC unit and a servo drive unit.

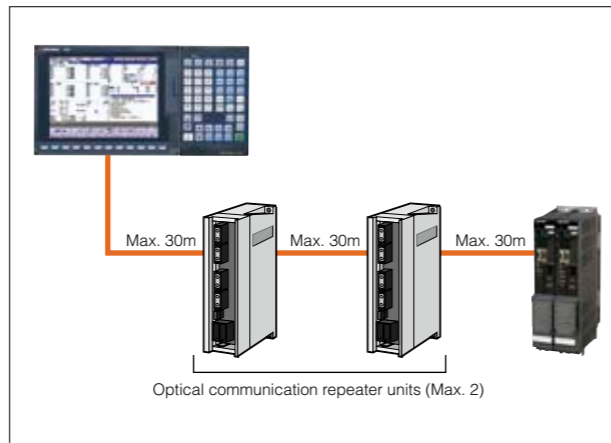

WARRANTY

Please confirm the following product warranty details before using MITSUBISHI CNC.

1. Warranty Period and Coverage

Should any fault or defect (hereafter called "failure") for which we are liable occur in this product during the warranty period, we shall provide repair services at no cost through the distributor from which the product was purchased or through a Mitsubishi Electric service provider. Note, however that this shall not apply if the customer was informed prior to purchase of the product that the product is not covered under warranty. Also note that we are not responsible for any on-site readjustment and/or trial run that may be required after a defective unit is replaced.

[Warranty Term]

The term of warranty for this product shall be twenty-four (24) months from the date of delivery of product to the end user, provided the product purchased from us in Japan is installed in Japan (but in no event longer than thirty (30) months, including the distribution time after shipment from Mitsubishi Electric or its distributor). Note that, for the case where the product purchased from us in or outside Japan is exported and installed in any country other than where it was purchased; please refer to "2. Service in overseas countries" as will be explained.

[Limitations]

- (1) The customer is requested to conduct an initial failure diagnosis by him/herself, as a general rule. It can also be carried out by us or our service provider upon the customer's request and the actual cost will be charged.
- (2) This warranty applies only when the conditions, method, environment, etc., of use are in compliance with the terms and conditions and instructions that are set forth in the instruction manual, user's manual, and the caution label affixed to the product, etc.
- (3) Even during the term of warranty, repair costs shall be charged to the customer in the following cases:
 - (a) a failure caused by improper storage or handling, carelessness or negligence, etc., or a failure caused by the customer's hardware or software problem
 - (b) a failure caused by any alteration, etc., to the product made by the customer without Mitsubishi Electric's approval
 - (c) a failure which may be regarded as avoidable, if the customer's equipment in which this product is incorporated is equipped with a safety device required by applicable laws or has any function or structure considered to be indispensable in the light of common sense in the industry
 - (d) a failure which may be regarded as avoidable if consumable parts designated in the instruction manual, etc. are duly maintained and replaced
 - (e) any replacement of consumable parts (including a battery, relay and fuse)
 - (f) a failure caused by external factors such as inevitable accidents, including without limitation fire and abnormal fluctuation of voltage, and acts of God, including without limitation earthquake, lightning, and natural disasters

- (g) a failure which is unforeseeable under technologies available at the time of shipment of this product from our company
- (h) any other failures which we are not responsible for or which the customer acknowledges we are not responsible for

2. Service in Overseas Countries

If the customer installs the product purchased from us in his/her machine or equipment, and export it to any country other than where he/she bought it, the customer may sign a paid warranty contract with our local FA center. This falls under the case where the product purchased from us in or outside Japan is exported and installed in any country other than where it was purchased. For details please contact the distributor from which the customer purchased the product.

3. Exclusion of Responsibility for Compensation against Loss of Opportunity, Secondary Loss, etc.

Whether during or after the term of warranty, we assume no responsibility for any damages arising from causes for which we are not responsible, any losses of opportunity and/or profit incurred by the customer due to a failure of this product, any damages, secondary damages or compensation for accidents arising under specific circumstances that either foreseen or unforeseen by Mitsubishi Electric, any damages to products other than this product, or compensation for any replacement work, readjustment and startup test run of on-site machines or any other operations conducted by the customer.

4. Changes in Product Specifications

Specifications shown in our catalogs, manuals or technical documents are subject to change without notice.

5. Product Application

- (1) For the use of this product, its applications should be those that may not result in a serious damage even if any failure or malfunction occurs in the product, and a backup or fail-safe function should operate on an external system to the product when any failure or malfunction occurs.
- (2) Mitsubishi CNC is designed and manufactured solely for applications to machine tools to be used for industrial purposes. Do not use this product in any applications other than those specified above, especially those which are substantially influential on the public interest or which are expected to have significant influence on human lives or properties.

Mitsubishi Factory Automation Solutions

- Our cultivated Factory Automation technologies and experience contribute to offer the best suited systems for users.
- Our FA solutions support high and low hierarchy components, a network and even applications that control the components and network required for a manufacturing floor.

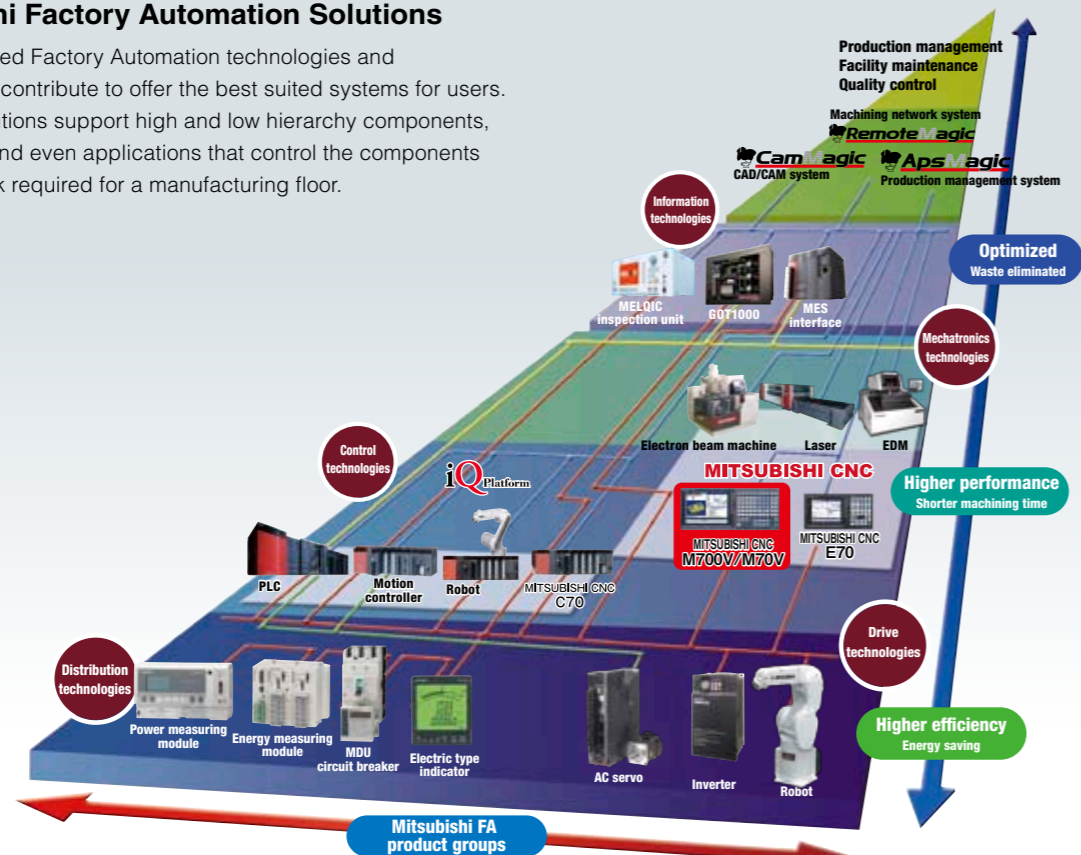

* Trademarks
 MELDAS, MELSEC, EZSocket, EZMotion, iQ Platform, MELSOFT, GOT, CC-Link, CC-Link/LT and CC-Link IE are either trademarks or registered trademarks of Mitsubishi Electric Corporation in Japan and/or other countries.
 Ethernet is a registered trademark of Xerox Corporation in the United States and/or other countries.
 Microsoft® and Windows® are either trademarks or registered trademarks of Microsoft Corporation in the United States and/or other countries.
 CompactFlash and CF are either trademarks or registered trademarks of SanDisk Corporation in the United States and/or other countries.
 Other company and product names that appear in this manual are trademarks or registered trademarks of the respective companies.

Specifications

○:Standard △:Optional

Specifications	Model name	Machining Center system		Lathe system	
		TypeB	TypeA	TypeB	TypeA
Number of control axes					
Max. number of axes (NC axes + Spindles + PLC axes)		9	11	9	11
Max. number of NC axes (in total for all the part systems)		5	8	5	9
Max. number of spindles		2	2	3	4
Max. number of PLC axes		6	6	6	6
Max. number of PLC indexing axes		4	4	4	4
Number of simultaneous contouring control axes		4	4	4	4
Max. number of NC axes in a part system		5	8	5	8
Max. number of part systems		1	2	1	2
Front IC card mode		○	○	○	○
Least command increment		0.1μm	0.1μm	0.1μm	0.1μm
Least control increment		1nm	1nm	1nm	1nm
Max. program capacity		○500kB [1,280m]	○500kB [1,280m] △2,000kB [5,120m]*1	○500kB [1,280m]	○500kB [1,280m] △2,000kB [5,120m]*1
Max. PLC program capacity		○20,000 steps	○32,000 steps	○20,000 steps	○32,000steps

*1:Additional hardware is required.

Displays & Keyboards

[mm]

		M70V			
Keyboard	Display	8.4-type	10.4-type	10.4-type touch panel	
Horizontal layout	FCU7-KB024 sheet keys FCU7-KB025 Lathe system sheet keys				
	FCU7-KB026 clear keys FCU7-KB028 Lathe system clear keys				
Vertical layout	FCU7-KB029 sheet keys				

The internal components of the keyboard are protected against water and oil (IP65F). The interface for the CF card is mounted on the front panel of the display.

Control Unit

The control unit is integrated into the back side of the display.

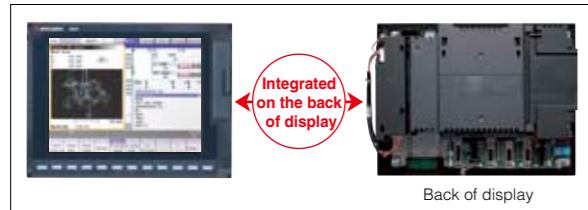

MITSUBISHI CNC Machine Operation Panel

[mm]

FCU7-KB921	Key switch 55 points, LED 55 points MITSUBISHI standard key layout	
FCU7-KB926	Rotary switches (spindle override, cutting override) Select switch (memory protection) Emergency stop push-button	

-The internal components of the machine operation panel are protected against water and oil (IP65F).
-Refer to the product brochure for details.

Drive Units

High-performance Servo/Spindle Drive Units MDS-D2/DH2 Series

- With the fastest current control cycle, basic performance is drastically enhanced (high-gain control). A combination of high-speed servo motor and high-accuracy detector helps enhance overall drive performance.
- A high-efficiency fin and low-loss power module have enabled unit downsizing. A line of drive units driving a maximum of two spindles is available, contributing to a reduction in control panel size.
- STO (safe torque off) is now available. (Note)



Multi-hybrid Drive Units MDS-DM2 Series

- A line of high-performance multi-hybrid drive units are available. The multi-hybrid drive unit drives a maximum of three servo axes and one spindle, supporting the downsizing of units and offering technical advantages.
- A power regeneration system that efficiently uses energy during deceleration as power contributes to highly-frequent acceleration/deceleration and energy savings.
- STO (safe torque off) is now available. (Note)



All-in-one compact drive units MDS-DJ Series

- Ultra-compact drive units with built-in power supplies contribute to reducing control panel size. The 2-axis type is added for further downsizing.
- High-speed optical communication enables a shorter position interpolation cycle and direct communication between drives, promoting further high-speed and high-accuracy machining.
- A high-efficiency fin and low-loss power module have enabled unit downsizing, which also leads to a reduction in control panel size.
- STO (safe torque off) is now available. (Note)



(Note) Please contact us for availability of STO as a whole system.

Servo Motors

HF Series

- High-inertia machine accuracy is ensured. Suitable for machines requiring quick acceleration.
- Range: 0.5 to 9 [kW]
- Maximum speed: 4,000 or 5,000 [r/min]
- Supports three types of detectors with a resolution of 260,000, 1 million or 16 million p/rev.



HF-KP Series

- Suitable for an auxiliary axis that require high-speed positioning
- Range: 0.1 to 0.75[kW]
- Maximum speed: 6,000 [r/min]
- Supports a detector with a resolution of 260,000p/rev.



Linear Servo Motor LM-F Series

- Use in clean environments is possible since no ball screws are used and therefore contamination from grease is not an issue.
- Elimination of transmission mechanisms which include backlash, enables smooth and quiet operation even at high speeds.
- Dimensions:
Length: 290 to 1,010 [mm]
Width: 120 to 240 [mm]



Direct Drive Servo Motor TM-RB Series

- High-torque direct-drive combined motor with a high-gain control system provides quick acceleration and positioning, which makes rotation smoother.
- Suitable for a rotary axis that drives a table or spindle head.
- Range:
Maximum torque: 36 to 1,280 [N·m]



Spindle Motors

High-performance New Type Spindle Motor SJ-D Series

- Motor energy loss has been significantly reduced by optimizing the magnetic circuit.
- Product line:
Normal SJ-D Series 3.7 to 11 [kW]
Compact & light SJ-DJ Series 5.5 to 15 [kW]



High-performance Spindle Motor SJ-V Series

- A vast range of spindle motors is available, all ready to support diversified machine tool needs.
- Product line:
Normal SJ-V Series 0.75 to 55 [kW]
Wide-range constant output SJ-V Series 5.5 to 18.5 [kW]
High-speed SJ-V-Z Series 2.2 to 22 [kW]
Hollow-shaft SJ-VS Series 5.5 to 18.5 [kW]



Low-inertia, High-speed New Type Spindle Motor SJ-DL Series

- Tapping machine-dedicated spindle motors have joined the new spindle motor line SJ-D Series in an effort to speed up drilling and tapping.
- The low-inertia reduces acceleration/deceleration time, resulting in higher productivity.
- Product line:
Low-inertia SJ-DL Series 0.75 to 7.5 [kW]



Low-inertia, High-speed Spindle Motor SJ-VL Series

- The spindle dedicated to tapping machines requiring faster drilling and tapping.
- The low-inertia reduces acceleration/deceleration time, resulting in higher productivity.
- Product line:
Low-inertia normal SJ-VL Series 3.0 to 11 [kW]
Low-inertia hollow shaft SJ-VLS Series 3.7 to 11 [kW]



Built-in Spindle Motor SJ-BG Series

- The optimized electrical design increases the continuous rated torque per unit volume compared to our conventional model, contributing to downsizing of the spindle unit.
- The mold with cooling jacket is available as an optional feature.



Tool Spindle Motor HF-KP/HF-SP Series

- Taking advantage of the characteristics of a servo motor such as smallness and high-output, this motor serves as a compact and high-output spindle motor which is capable of high-speed rotation (6,000r/min). This motor contributes to downsizing of spindles, such as the rotary tool spindle.
- Product line:
Small capacity HF-KP Series 0.4 to 0.9 [kW]
Medium capacity HF-SP Series 2.2 to 4 [kW]



Refer to the specifications manuals.

 **Safety Warning**

To ensure proper use of the products listed in this catalog, please be sure to read the instruction manual prior to use.

Mitsubishi Electric Corporation Nagoya Works is a factory certified for ISO14001 (standards for environmental management systems) and ISO9001 (standards for quality assurance management systems)



for a greener tomorrow

Eco Changes is the Mitsubishi Electric Group's environmental statement, and expresses the Group's stance on environmental management. Through a wide range of businesses, we are helping contribute to the realization of a sustainable society.



MITSUBISHI ELECTRIC CORPORATION

HEAD OFFICE: TOKYO BLDG., 2-7-3, MARUNOUCHI, CHIYODA-KU, TOKYO 100-8310, JAPAN
<http://Global.MitsubishiElectric.com>

BNP-A1218-F[ENG]
(ENGLISH)